

RE-VERBER-RAY®

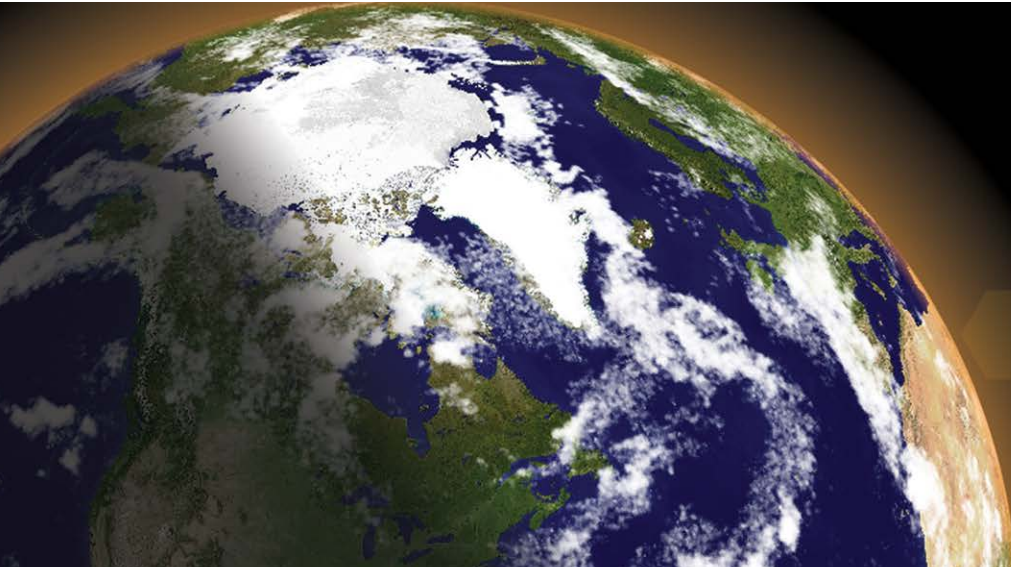

Brant Radiant Heaters Limited

**MANUFACTURER OF GAS-FIRED INFRARED
RADIANT HEATING EQUIPMENT SINCE 1965**



**GLOBAL PROVIDER of
ENERGY EFFICIENT
BUILDING SOLUTIONS**



High Intensity Infrared
Space Heaters



High Intensity Infrared
Patio Heaters



Low Intensity Infrared
Tube Heaters



Warm Air Unit Heaters



Industrial LED Lights



Electric Infrared Heaters



ABOUT BRANT RADIANT HEATERS LIMITED

Who We Are

Since 1965, Brant Radiant Heaters Limited has set the standard for high-quality, cost-effective, energy-efficient infrared heaters. Our vertically integrated manufacturing capabilities allow us to exceed your expectations in quality, flexibility, design and service. By choosing the Re-Verber-Ray® brand you secure a solution for the most demanding commercial, industrial and specialty applications.



TRUST



EXPERTISE



SUPPORT



HISTORY



LOYALTY



TECHNOLOGY

Where We Do It

Located in Canada, our Paris, Ontario plant and surrounding facilities in Michigan have over 200,000 ft² of manufacturing space with dedicated press rooms, five production lines, a certified testing laboratory, and a classroom. Our customer service team, technical support staff and design assistance cell are centrally located at the factory. All this capability means you get your product how you want it, where you want it, and when you want it.

THE EFFICIENCY OF INFRARED HEATING

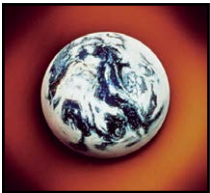

Re-Verber-Ray® infrared heaters emulate the true efficiency of the sun. Infrared heaters generate energy which is converted into heat when absorbed by floors, animals, people and objects. This energy is then re-radiated to warm the surrounding area by convection. This is the most efficient and effective method of heating under the diverse and challenging conditions present in most commercial and industrial applications.

COMMON APPLICATIONS

- Auto Service Shops
- Farm Buildings
- Ice Rinks
- Home Garages
- Car Washes
- Warehouses
- Manufacturing Facilities
- Confinement Barns
- Vehicle Maintenance Facilities
- and Many More!

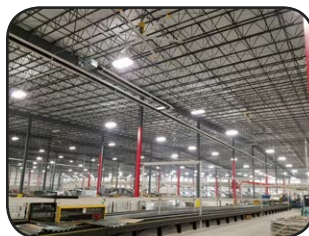

Warehouses



Outdoor Patios



Loading Docks



Municipal Facilities



Aircraft Hangars



Entrance Ways

TRADITIONAL BENEFITS OF INFRARED

- **Fuel Savings:** 20-50% over conventional forced air units.
- **Flexibility:** Heaters can be placed where most needed.
- **Modular Design:** Re-Verber-Ray® heaters are of a modular design to assure heating protection over traditional central heating systems.
- **Superior Comfort:** Heat the floor zone, not the ceiling.
- **Radiant Efficiency:** Output is enhanced through a highly emissive, black coated radiant tube chamber or perforated ceramic.
- **Durability:** Infrared heaters require very little maintenance and are much easier to clean than air tempering and recirculating systems.
- **Quiet & Clean:** No noisy blowers pushing dirt and dust around.

Heat the People Zone...

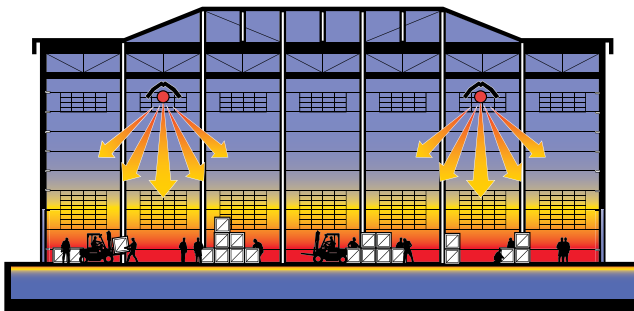

INFRARED HEATING SYSTEM

...Not the Empty Spaces.

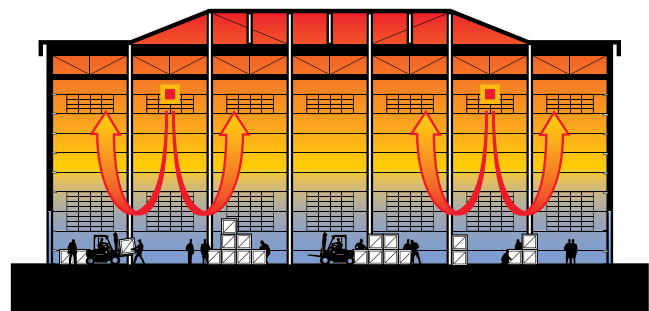

FORCED AIR HEATING SYSTEM

FUEL SAVING STUDIES

Proven Average Fuel Savings of 23 Percent*

It is proven that gas fired infrared heaters save energy, and therefore dollars, over traditional hot air heating systems. Brant Radiant Heaters Limited is committed to documenting these savings through independent, scientifically conducted studies.

A three-year independent field test was conducted to determine the effectiveness of a two-stage heating system and how it meets heat requirements more efficiently vs. forced air heating systems. An accurate side-by-side evaluation of the different heating systems revealed that infrared heaters proved **23% fuel savings** and **improved comfort levels** over a forced air heating system.

Market proven results show **energy costs reduced by as much as 50%** with fixed input infrared heaters when compared to forced air heating.

For more information on how infrared heating can make a difference for you, visit our website or contact us today!

* As reported in ASHRAE Research Project Number 4643. Results may vary depending on application.

LOW INTENSITY HEATER PRODUCT OFFERING

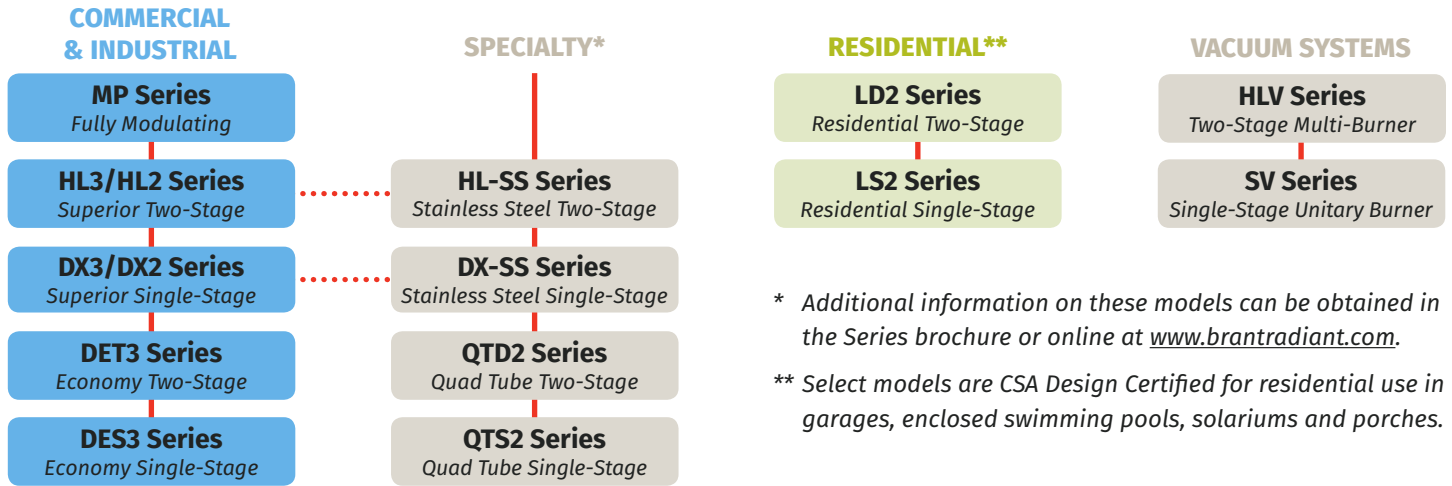

* Additional information on these models can be obtained in the Series brochure or online at www.brantradiant.com.

** Select models are CSA Design Certified for residential use in garages, enclosed swimming pools, solariums and porches.

NOT ALL INFRARED HEATERS ARE DESIGNED ALIKE

Modulating & Two-Stage

Choice of two advanced operating technologies.

Burner Design

A burner that produces an elongated and spiraled flame is superior to a "cup" style burner that produces a shortened flame. An elongated flame emits more flame radiation than other flames and improves heat distribution. Brant Radiant's stainless steel burner is specifically designed for an elongated flame.

Tube Construction

Our "labour saving" interlocking swaged radiant tubes are constructed of stainless steel, titanium stabilized, aluminized coated and/or hot-rolled steel. Different tube materials are subject to different tolerances to heat and corrosion. Quality tube exchanger materials provide increased equipment longevity and when coated with a highly emissive (.95+) black tube coating, infrared heat output is also enhanced.

Reflector

Highly polished aluminum reflectors transmit nearly 90% of radiant energy, while mill finish reflectors may only achieve a reflective value of 65%. Core reflector material is the most critical concern when evaluating reflector design.

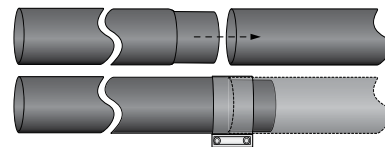
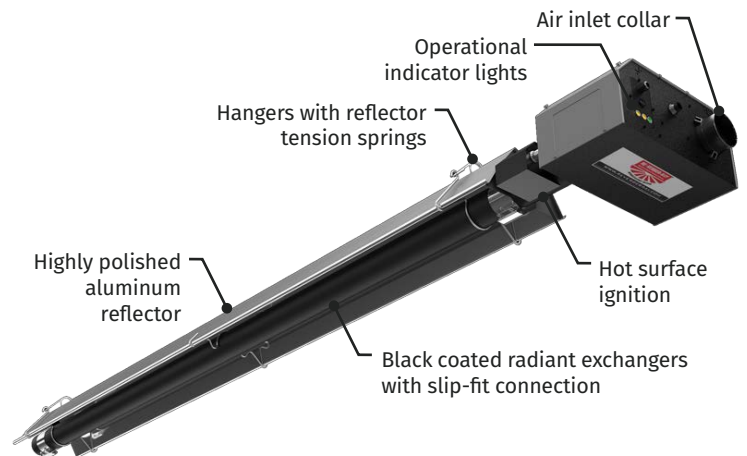

Black Coated "Labor Saving", Interlocking, Slip-Fit Exchanger Tubes

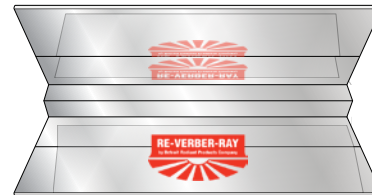

Highly Polished Reflectors



Learn more at www.youtube.com/reverberry

FULLY MODULATING

The MP Series is the ONLY infrared heater that puts YOU in control!
Ideal for those seeking a heater with advanced operating flexibility.

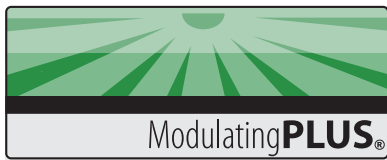

NOT FOR RESIDENTIAL USE!



MP Series Fully Modulating, Low Intensity Tube Heater

The MP Series fully modulating infrared heater is the only infrared heater that allows you to select the desired performance curve that best suits your building requirements.

The MP Series raises the bar with modulating technology. This full air and gas modulation line of heaters incorporates cutting edge technology such as the selection of three different performance curves as well as a 'Blast Mode'™ feature for extreme environmental demands.

MP Product Specifications:

BTU Range: 80,000 to 200,000 BTU/h (Nat. or Prop. Gas)
Lengths: 25 to 70 Feet
Limited Warranty: 3-5-10 (Components-Tubes-Burner)
Combustion Tube(s): 4" Black Coated Titanium Stabilized/Aluminized Steel
Radiant Tube(s): 4" Black Coated Aluminized Steel

MP Series Features:

- 'Blast Mode'™ feature allows the user to temporarily lock the heater into its highest input plus an extra 5,000 BTU's for extreme environmental demands.
- Full gas modulation with corresponding air flow modulation to achieve optimal fuel utilization and comfort levels.
- Forced high-fire start up for faster response to the environmental demand.
- Full proportional-integral-derivative (PID) logic to reduce on/off cycles over traditional heat.

MP Series Performance Curves/Mode Selection

The MP Series is programmed to operate on three performance curves allowing the user to select the desired operation that best accommodates their specific needs.

'Comfort Mode': Unit operates to minimize temperature differentials across the length of the heater. It is intended to provide a system that has a greater perceived comfort than the other modes due to more even dissipation of heat.

'Standard Mode': Unit operates as a balance between Comfort Mode and Economy Mode. It is intended to provide a system that is moderately thermal efficient while minimizing temperature differentials associated with economy mode.

'Economy Mode': Unit operates to maximize thermal efficiency. It is designed to provide a system that is more thermally efficient than the other modes due to quicker dissipation of heat.

Mode Selection / Application Chart		
Comfort	Standard Mode	Economy Mode
<ul style="list-style-type: none"> • Patios • Loading docks • Break areas and lunch rooms • Kennels • Parts counters and service desks • Golf driving ranges • Woodworking shops 	<ul style="list-style-type: none"> • Service garages • Fire stations • Populated warehouse heating • Manufacturing • Auto showrooms 	<ul style="list-style-type: none"> • Aircraft hangars • Car washes • Pole barns • Foundries • Unpopulated warehouses

SUPERIOR TWO-STAGE

The HL3/HL2 Series is ideal for those seeking a heater that offers optimal fuel and comfort benefits with unsurpassed features.

HL3 Series



HL2 Series

NOT FOR RESIDENTIAL USE!



HL3/HL2 Series Premier, Two-Stage, Low Intensity Tube Heater

The HL3/HL2 Series couples the energy savings of two-stage technology with the highest quality features available in any infrared heating equipment. Features include a specially designed stainless steel burner and highly emissive black coated, aluminized steel radiant tubes. Benefits of the HL3/HL2 Series include superior fuel economy, comfort levels and equipment longevity. The two-stage HL3/HL2 Series represents the **BEST** in performance and quality!

HL3/HL2 Product Specifications:

BTU Range:	65,000 to 200,000 BTU/h (Nat. or Prop. Gas)
Lengths:	20 to 70 Feet
Limited Warranty:	3-5-10 (Components-Tubes-Burner)
Combustion Tube(s):	4" Black Coated Titanium Stabilized/Aluminized Steel
Radiant Tube(s):	4" Black Coated Aluminized Steel

HL3/HL2 Series Features:

- Patented two-stage operation.
- Pre- and post-purge controls.
- Operational indicator lights.
- Self-diagnostic LED, microprocessor based circuitry.

Stainless steel upgrades available for harsh environments.

SUPERIOR SINGLE-STAGE

The DX3/DX2 Series is ideal for those seeking a high-end single stage tube heater with all essential, plus many value-added, features.

DX3 Series



DX2 Series

NOT FOR RESIDENTIAL USE!



DX3/DX2 Series Premier, Single-Stage, Low Intensity Tube Heater

The DX3/DX2 Series represents the highest quality single-stage low intensity heater available. Performance is enhanced through the use of a specially designed stainless steel burner and black coated, titanium stabilized and/or aluminized coated steel radiant tube exchangers. The DX3/DX2 Series offers superior low intensity heat, performance, and longevity. The DX3/DX2 Series is designed to provide years of reliable, trouble-free service.

DX3/DX2 Product Specifications:

BTU Range:	50,000 to 200,000 BTU/h (Nat. or Prop. Gas)
Lengths:	20 to 80 Feet
Limited Warranty:	3-5-10 (Components-Tubes-Burner)
Combustion Tube(s):	4" Black Coated Titanium Stabilized/Aluminized Steel
Radiant Tube(s):	4" Black Coated Aluminized Steel

DX3/DX2 Series Features:

- Pre- and post-purge controls.
- 24" stainless steel flexible gas connector.
- Operational indicator lights.
- Potted (water resistant) circuitry.
- Hot surface ignition.

Stainless steel upgrades available for harsh environments.

ECONOMY SERIES

Economy heaters are ideal for those seeking an economical two-stage or single-stage heater with limited features.



NOT FOR RESIDENTIAL USE!



DET3 Series Economical, Two-Stage, Low Intensity Tube Heater **DES3 Series** Economical, Single-Stage, Low Intensity Tube Heater

Streamlined for economy and designed without sacrificing burner performance, both the DET3 and DES3 Series are quality, energy efficient heaters at a more economical price. Our patented two-stage technology incorporated into the DET3 Series, provides more comfort while saving valuable energy dollars.

Product Specifications:

BTU Range:	50,000 to 200,000 BTU/h (Nat. or Prop. Gas)
Lengths:	20 to 60 Feet
Limited Warranty:	1-3-5 (Components-Tubes-Burner)
Combustion Tube(s):	4" Black Coated Titanium Stabilized/Aluminized Steel
Radiant Tube(s):	4" Hot-Rolled Steel

Series Features:

- Direct spark ignition.
- Operational indicator lights (DET3).
- Interlocking, slip-fit tube exchangers.

LOW MOUNT / LOW BTU / RESIDENTIAL*

Residential heaters* are ideal for those seeking a two-stage or single-stage tube heater for areas with low mounting heights or heat loads.



Patent Pending



LD2 Series Low Mount, Two-Stage, Low Intensity Tube Heater **LS2 Series** Low Mount, Single-Stage, Low Intensity Tube Heater

*Reference product specifications for models that are CSA Design Certified for residential use.

Product Specifications:

BTU Range:	25,000 to 50,000 BTU/h (Nat. or Prop. Gas)
Lengths:	10 to 30 Feet
Limited Warranty:	1-3-5 (Components-Tubes-Burner)
Combustion Tube(s):	3" to 4" Black Coated Titanium Stabilized Steel
Radiant Tube(s):	3" Black Coated Aluminized Steel

Series Features:

- Operational indicator lights.
- Hot surface ignition.
- Low mounting heights.



Residential Garage

VACUUM SYSTEMS

Vacuum systems are ideal for those seeking an energy efficient heating system and/or as a solution in applications with unique design challenges.

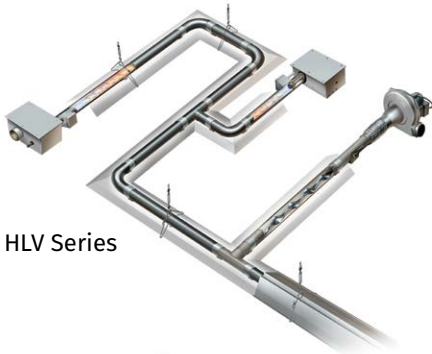

HLV Series



SV Series in "U"
Configuration

NOT FOR RESIDENTIAL USE!



HLV Series *Two-Stage, Multiple Burner, Vacuum System* **SV Series** *Single-Stage, Unitary, Vacuum Tube Heater*

Vacuum systems operate under a negative pressure pulling the products of combustion through the length of the exchanger tubes via a powerful vacuum exhauster pump. This type of heater offers reliable performance in high wind applications, requires minimal building penetrations and can allow for extended venting runs. Key operational features include a 20% reduction in output when operating in low fire and stainless steel tailpipe when optional condensing operation is utilized.

Product Specifications:

BTU Range: 40,000 to 200,000 BTU/h per Burner (Nat. or Prop. Gas)

Lengths: Varies by Design

Limited Warranty: 3-5-10-1 (Components-Tubes-Burner-Pump)

Combustion Tube(s): 4" Black Coated Titanium Stabilized/Aluminized Steel

Radiant Tube(s): Option to select type Aluminized or Hot-Rolled Steel

Series Features:

- Self-diagnostic circuitry.
- Operational indicator lights.
- Extended vacuum system runs.
- Reliable performance in high wind conditions.

LOW INTENSITY COMFORT HEATERS

The QT2 Series unique design provides superior performance and is ideal for applications seeking even heat intensity.



Patent No. 12/889,814

NOT FOR RESIDENTIAL USE!



QTD2 Series *Quad Tube, Multi-Burner, Two-Stage Low Intensity* **QTS2 Series** *Quad Tube, Multi-Burner, Single-Stage Low Intensity*

The QT2 Series Patent Pending design captures operational benefits of both high and low intensity infrared heaters. Its unique construction features include a multi-burner, multi-exchanger platform optimized for a broad and even heat output pattern without hot spots. Available in both single and dual stage operation, this heater provides application versatility unmatched by traditional infrared solutions.

Series Features:

- CSA Design Certified for both indoor and outdoor use.
- Compact, aesthetically pleasing construction.
- Easy to install with minimal assembly required.
- Proven reduced energy consumption characteristics.
- Multiple construction features including: dual spark ignition, highly emissive heat exchangers, polished reflectors, operational indicator lights and more.
- Designed and packaged for ease in transportation.

DESIGNER SERIES LOW INTENSITY

Specifically designed for comfort and reliability. Ideal for outdoor driving ranges and restaurant patios.



DST Series
26 Linear Feet of Radiant Tube
Get the most radiant surface area from any 10 ft. radiant patio heater available!



HL2-DS Series
Custom cast U-bend doubles the linear feet of radiant pipe.

NOT FOR RESIDENTIAL USE!



DST Series *Two-Stage, Gas-Fired, Low Intensity Patio Heater* **HL2-DS** *Two-Stage, Gas-Fired, Decorative, Low Intensity Tube*

The DST & HL2-DS Series are a top-of-the-line patio heater with an aesthetically pleasing, modern design featuring our patented two-stage technology. These heaters were manufactured specifically for the outdoor market in mind. Not only do these heaters deliver an even heat pattern throughout its span, but it also comes equipped with a decorative, modular grille.

DST Product Specifications:

BTU Input:	60,000 BTU/h (High Fire); 40,000 BTU/h (Low Fire) (Nat. or Prop. Gas)
BTU Input:	80,000 BTU/h (High Fire); 40,000 BTU/h (Low Fire) (Nat. Gas only; Outdoor use only)
Length:	26 linear feet of tube contained in 119 Inches
Limited Warranty:	3-5-10 (Components-Tubes-Burner)

HL2-DS Product Specifications:

BTU Range:	65,000 to 100,000 BTU/h (Nat. or Prop. Gas)
Length:	Max. linear feet of tube contained in decorative casing
Limited Warranty:	3-5-10 (Components-Tubes-Burner)

Series Features:

- High/low fire BTU selection.
- Smart LED self-diagnostics.

UNIT HEATERS

Gas-fired unit heaters offer another option where infrared heating is not practical due to ceiling heights, clearance to combustibles or building use.



UH Series *Gas-Fired, Separated Combustion Unit Heater* **FA Series** *Gas-Fired, Separated Combustion Unit Heater*

Compact, aesthetically pleasing construction with standard features such as out-of-the-box separated combustion or power vented, stainless steel discharge louvers, aluminized steel heat exchangers, operational indicator lights and finger-proof fan guards.

UH Series Features:

- 30,000 - 75,000 BTU/h (Nat. or Prop. Gas)
- Models can be rotated 180 degrees and are residentially approved.

FA Series Features:

- 100,000 - 250,000 BTU/h (Nat. or Prop. Gas)



HIGH INTENSITY HEATERS

The DR Series is ideal for unvented spot heating applications or in applications where unvented high intensity heat offers design benefits or is preferred.

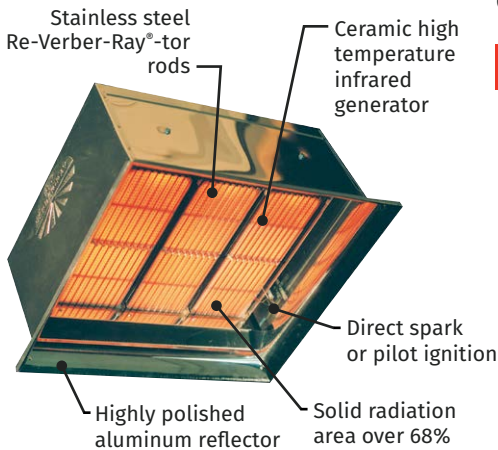

NOT FOR RESIDENTIAL USE!



DR Series Gas Fired, High Intensity, Unvented Infrared Heater

The DR Series is commonly used in areas of high air infiltration, high ceilings and/or spot heating applications. The DR Series is available in a multitude of configurations, ranging from 30 to 160 MBH with 6 different control options.

Series Features:

- 5-year limited warranty.
- Exclusive Re-Verber-Ray® ceramic burner provides maximum conversion to infrared radiation.
- CSA Design Certified, UL Listed, accepted by FIA and FM.
- Available in 6 control configurations from manual to solid state ignition.
- Lower installation costs through compact modular heater design.
- Rugged, non-corrosive, materials in heater construction.
- Proven design – over 2,000,000 burners in use.
- Re-Verber-Ray®-tor rods increase heater temperature and efficiency.
- 35 ft. wire and thermostat included with each millivolt unit.

PATIO HEATERS

Patio heaters are ideal for those seeking to provide comfort primarily to outdoor applications.

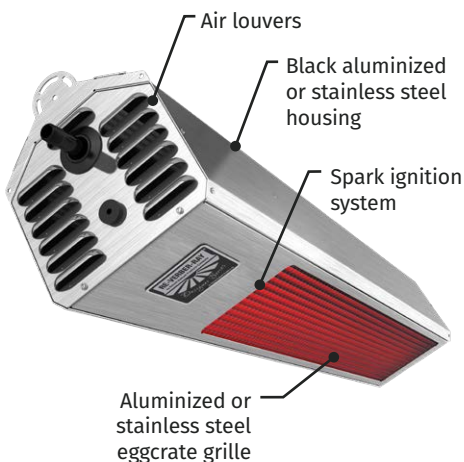

NOT FOR INDOOR RESIDENTIAL USE!



DSCS Series Gas Fired, High Intensity, Infrared Patio Heater

Designed to add warmth to outdoor patio applications, the Designer Series infrared heater is the perfect solution to stylishly extend the outdoor season to many commercial and outdoor residential applications. The Designer Series easily mounts out of the way and without the hassle of refilling propane tanks and is sure to deliver the desired amount of warmth for dining, entertainment or work areas.

Product Specifications:

BTU Input: 34,000 BTU/h (Nat. Gas) or 31,000 BTU/h (Nat. or Prop. Gas)

Limited Warranty: 1 Year Controls, 5 Years Burner

Series Features:

- ETL Design Certified for indoor and outdoor use.
- Decorative aluminum or stainless steel, 3/4" eggcrate grille.
- Wind and rain protected design.
- Reliable direct spark ignition.
- Potted (water resistant) 24V circuitry.
- Black coated aluminized steel or brushed stainless steel housing.

ELECTRIC HEATERS

Electric infrared heaters are the cleanest method of heating, taking nothing from the air and adding nothing to the air.



Certified for indoor or outdoor use.



CE Certified for indoor or outdoor use. IP55 weatherproof.

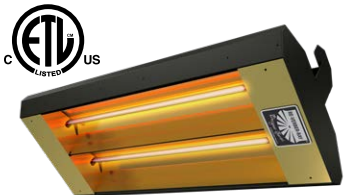

Certified for indoor or outdoor use.

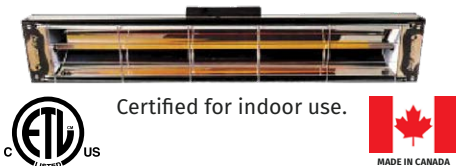

Certified for indoor use.

Electric infrared heaters are the answer to applications where gas or ventilation is not available or is impractical producing quiet, clean, even, energy-efficient heat in a compact, aesthetically pleasing construction.

NOT FOR RESIDENTIAL USE!

SW Series *Short-Wave Electric, High Intensity Infrared*

- From 1,600 to 11,400 watt output.
- Single, double or triple construction models.
- Available in either black powder coated aluminized steel or brushed 304 grade stainless steel housing.
- Choice of clear quartz lamps or glare reducing ruby quartz lamps.

DGS Series *Filtered Short-Wave Electric Infrared*

- Available in 1,500, 2,000 and 3,000 watts.
- Bronze-colored housing with custom designed reflector.
- High-end quality and compact, aesthetic design.
- High-capacity gold filtered red lamps.

MW Series *Medium-Wave Electric, High Intensity Infrared*

- 120V-575V range available in lengths of 24", 33" & 46".
- Single, double or triple chassis design.
- Available in either black powder coated aluminized steel or brushed 304 grade stainless steel housing.
- Quartz tube element for a softer look and radiant heat output.

BAH Series *Medium-Wave Electric, High Intensity Infrared*

- Choose 120, 208, 240, 480 or 575 volts.
- 6 different kW models available, ranging from 0.5kW to 4.0kW.
- Virtually instant heat with glass encased "quartz" tube element.
- Aesthetically pleasing, black coated chassis design.

INDUSTRIAL LED LIGHTING

Re-Verber-LYT LED Lighting *Innovative, Energy-Saving, Lighting Solutions*



LED bay lights are specifically designed for large industrial areas because they are highly durable. They were made to emit more light energy at long ranges. This is the most energy efficient option in the market.

Round high-bay and low-bay LED lighting is perfect for warehouses, factories and auto shops because they improve visibility and enhance productivity! Rectangular LED fixtures are a traditional style lighting method that create wide arrays of light and are easily installed. They are often used to eliminate fluorescent lamp/ballast maintenance costs.

Visit www.reverberlyt.com for more information.

CERTIFYING AGENCIES AND ASSOCIATIONS

Re-Verber-Ray® products are recognized not only for efficiency, but also for safety. When installed according to the written instructions, our heaters meet or exceed the Standards set forth by:

Canadian Standard Association (CSA)



CSA is a Nationally Recognized Testing Laboratory (NRTL) that conducts certification testing to national standards. Many products manufactured by Brant Radiant Heaters bear the CSA mark and are design certified.

Design Lights Consortium (DLC)



The DLC® is a non-profit organization whose mission is to drive efficient lighting by defining quality, facilitating thought leadership, and delivering tools and resources to the lighting market through open dialogue and collaboration.

Underwriters Laboratory (UL)



UL is a Nationally Recognized Testing Laboratory (NRTL) that conducts certification testing to national standards. Detroit Radiant Products in association with Brant Radiant Heaters utilizes UL for limited compliance testing and select units bear the UL mark.

Edison Testing Laboratories (ETL)



Intertek is a Nationally Recognized Testing Laboratory (NRTL) that conducts certification testing to national standards. The ETL mark is proof of product compliance issued by Intertek. Brant Radiant Heaters utilizes Intertek for some compliance testing and select units bear the ETL mark.

European Conformity (CE)



CE is the European Conformity marking that indicates that the product complies with the essential requirements of the relevant European health, safety, and environmental protection legislation. Detroit Radiant Products in association with Brant Radiant Heaters offers many products that bear the CE mark of conformity.

Infrared Heater Safety Council (IRSC)



The IRSC is a council that educates building inspectors, fire authorities, and end users of safe practices pertaining to infrared heaters. Detroit Radiant Products in association with Brant Radiant Heaters has been a participating member since its foundation in 2007.

US Green Building Council (USGBC)



The USGBC is a nonprofit trade organization that oversees the LEED certification program. Detroit Radiant Products in association with Brant Radiant Heaters has been a member of the USGBC since 2009, and is proud to have a LEED Accredited Professional on staff.

ISO/IEC Certified Laboratory



The International Standards Organization is the world's largest developer and publisher of international standards. Detroit Radiant Products' in association with Brant Radiant Heaters on-site laboratory is certified as an approved testing facility.

www.brantradiant.com

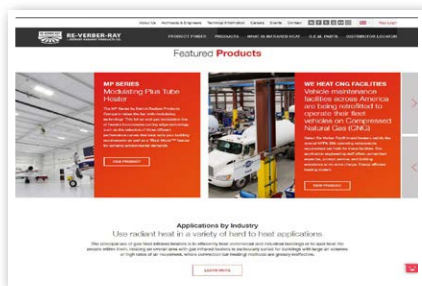

Brant Radiant Heaters Limited offers the most complete and interactive website amongst infrared manufacturers. This site is designed with specifying engineers, installing contractors and end users in mind.

- Product Literature
- Design and Application Guides
- CAD/Revit Drawing Library
- Local Representative Locator
- Troubleshooting Assistance
- Online Replacement Parts Library
- Online Product Registration



BRANT RADIANT HEATERS LIMITED

34 Scott Ave., Paris, ON N3L 3R1
Voice: (519) 442-7823
Toll Free: (800) 387-4778
Fax: (519) 442-7321
Website: www.brantradiant.com
E-mail: sales@brantradiant.com

DISTRIBUTED BY:

