

BRANT RADIANT HEATERS LTD.

Wiring Diagram for Suffix NE-2 25V and 120V

(Pilot Sensing Element - SPDT Mercury Element)

TYPICAL WIRING SCHEMATIC

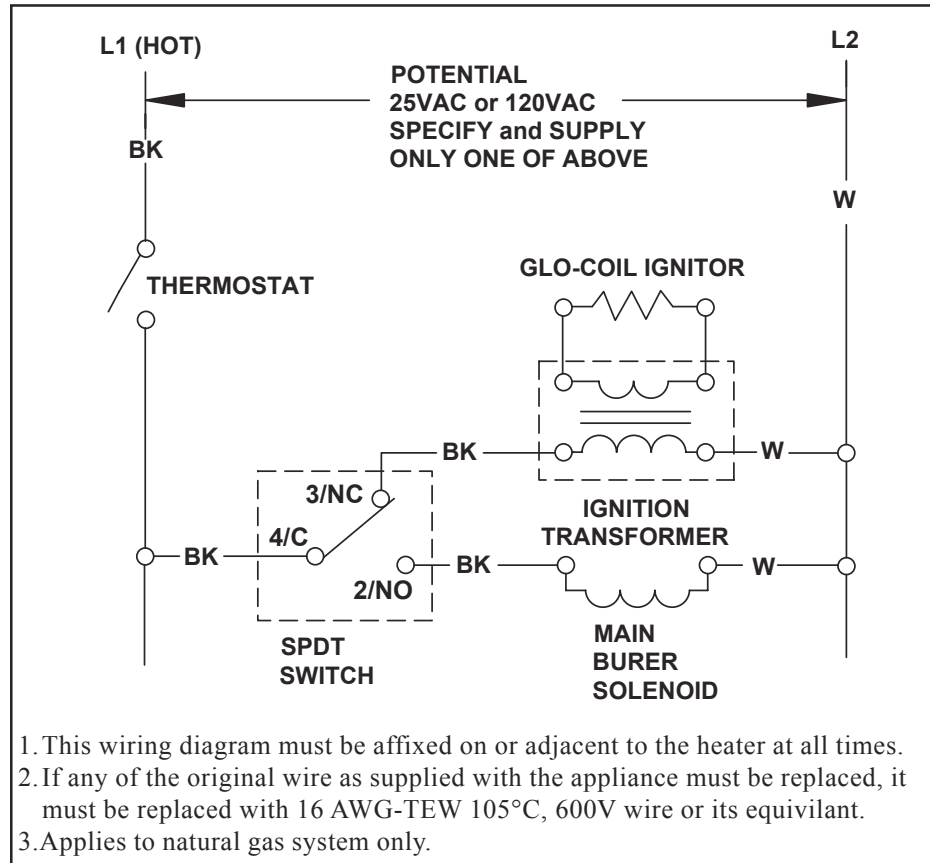

TYPICAL BLOCK DIAGRAM

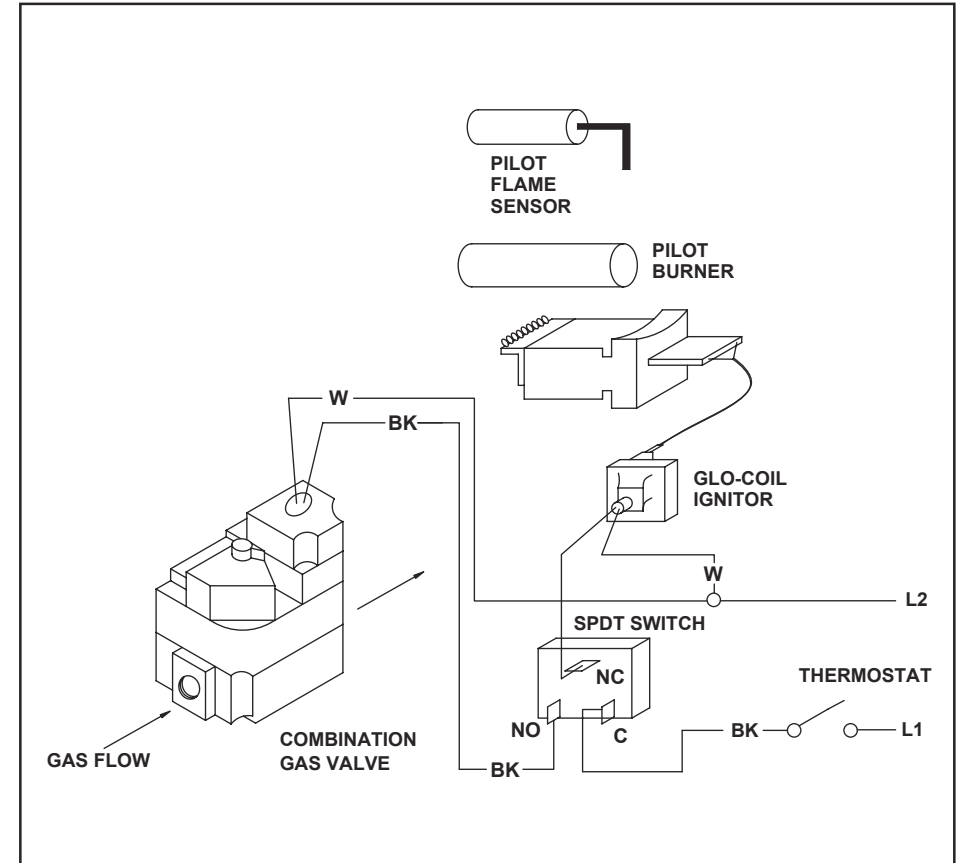

BRANT RADIANT HEATERS LTD.

Wiring Diagram for Suffix NE-2 25V and 120V

(Pilot Sensing Element - SPDT Mercury Element)

Normal Sequence of Operation

Closing of the electrical circuit, upon demand for heat, the following occurs:

1. The system's ignition transformer is energized resulting in the heating of the glo-coil filament.
2. The pilot burner gas is ignited and a subsequent heating of the pilot sensing element, a mercury single-pole, double-throw pilot switch, occurs.
3. Upon adequate heating, the pilot sensing element switches from its normally closed position - causing the glo-coil ignition transformer to be de-energized to its normally open position.
4. The heater's main burner solenoid valve is enlarged and opens, resulting in the operation of the heater.